



# Atlas One Step Cocaine Test Cassette (Urine)

*A rapid, one step test for the qualitative detection of Cocaine metabolites in human urine.  
For professional in vitro diagnostic use only.*

## INTENDED USE

Atlas One Step Cocaine Test Cassette (Urine) is a rapid chromatographic immunoassay for the qualitative detection of Cocaine metabolite, Benzoyllecgonine, in human urine at a cut-off concentration of 300 ng/mL.

**This assay provides only a qualitative, preliminary analytical test result. A more specific alternate chemical method must be used in order to obtain a confirmed analytical result. Gas chromatography/mass spectrometry (GC/MS) is the preferred confirmatory method. Clinical consideration and professional judgment should be applied to any drug of abuse test result, particularly when preliminary positive results are used.**

## SUMMARY

Cocaine is a potent central nervous system (CNS) stimulant and a local anesthetic. Initially, it brings about extreme energy and restlessness while gradually resulting in tremors, over-sensitivity and spasms. In large amounts, Cocaine causes fever, unresponsiveness, and difficulty in breathing and unconsciousness.

Cocaine is often self-administered by nasal inhalation, intravenous injection and free-base smoking. It is excreted the urine in a short time primarily as Benzoyllecgonine. Benzoyllecgonine, a major metabolite of Cocaine, has a longer biological half-life (5 - 8 hours) than Cocaine (0.5 - 1.5 hours), and can generally be detected for 24-48 hours after Cocaine exposure.

Atlas One Step Cocaine Test Cassette (Urine) is a rapid urine-screening test that can be performed without the use of an instrument. The test utilizes a monoclonal antibody to selectively detect elevated levels of Cocaine metabolite in urine. Atlas One Step Cocaine Test Cassette (Urine) yields a positive result when the Cocaine metabolite in urine exceeds 300 ng/mL. This is the suggested screening cut-off for positive specimens set by the Substance Abuse and Mental

Health Services Administration (SAMHSA, USA).

## PRINCIPLE

Atlas One Step Cocaine Test Cassette (Urine) is an immunoassay based on the principle of competitive binding. Drugs which may be present in the urine specimen compete against the drug conjugate for binding sites on the antibody. During testing, a urine specimen migrates upward by capillary action. Benzoyllecgonine, if present in the urine specimen below 300 ng/mL, will not saturate the binding sites of antibody in the test Cassette. The antibody-coated particles will then be captured by immobilized Benzoyllecgonine conjugate and a visible colored line will appear in the test line region. The colored line will not form in the test line region if the Benzoyllecgonine level is above 300 ng/mL because it will saturate all the binding sites of antibodies.

A drug-positive urine specimen will not generate a colored line in the test line region because of drug competition, while a drug-negative urine specimen or a specimen containing a drug concentration less than the cut-off will generate a line in the test line region. To serve as a procedural control, a colored line will always appear at the control line region indicating that proper volume of specimen has been added and membrane wicking has occurred.

## REAGENTS

The test Cassette contains mouse monoclonal anti-Benzoyllecgonine antibody-coupled particles and Benzoyllecgonine-protein conjugate. A goat antibody is employed in the control line system.

## PRECAUTIONS

- For professional *in vitro* diagnostic use only. Do not use after the expiration date.
- The test Cassette should remain in the sealed pouch until use.
- All specimens should be considered potentially hazardous and handled in the same manner as an infectious agent.
- The used test Cassette should be discarded in a proper biohazard container after testing.

## STORAGE AND STABILITY

The kit can be stored at room temperature or refrigerated (2-30°C). The test Cassette is stable through the expiration date printed on the label on the sealed pouch. The test Cassette must remain in the sealed pouch until use. **DO NOT FREEZE.** Do not use beyond the expiration date.

## SPECIMEN COLLECTION AND PREPARATION

### Urine Assay

The urine specimen must be collected in a clean and dry container. Urine collected at any time of the day may be used. Urine specimens exhibiting visible precipitates should be centrifuged, filtered, or allowed to settle to obtain a clear supernatant for testing.

## Specimen Storage

Urine specimens may be stored at 2-8°C for up to 48 hours prior to testing. For prolonged storage, specimens may be frozen and stored below -20°C. Frozen specimens should be thawed and mixed before testing.

## MATERIALS

### Materials Provided

- Test Cassette.
- Disposable specimen droppers
- Package insert.

### Materials Required But Not Provided

- Specimen collection container
- Timer
- External controls

## DIRECTIONS FOR USE

**Allow the test Cassette, urine specimen, and/or controls to equilibrate to room temperature (15-30°C) prior to testing.**

1. Bring the pouch to room temperature before opening it. Remove the test Cassette from the sealed pouch and use it as soon as possible.
2. Place the test device on a clean and level surface. Hold the dropper vertically and **transfer 3 full drops of urine** (approx. 100µl) to the specimen well (S) of the test device, and then start the timer. Avoid trapping air bubbles in the specimen well (S). See the illustration below.
3. Wait for the red line(s) to appear. The result should be **read at 5 minutes**. It is important that the background is clear before the result is read. Do not interpret the result after 10 minutes.

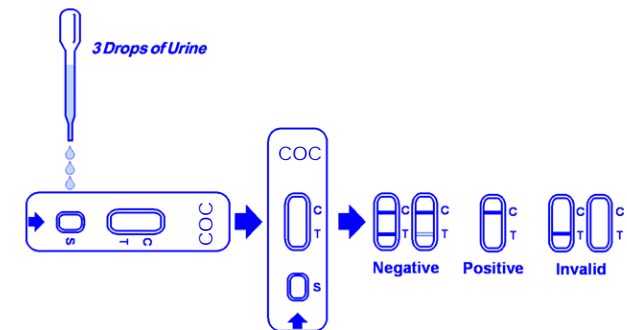

## INTERPRETATION OF RESULTS

(Please refer to the illustration above)

**NEGATIVE: Two lines appear.** One red line should be in the control region (C), and another apparent red or pink line should be in the test region (T). This negative result indicates that the Benzoyllecgonine concentration is below the detectable level (300 ng/mL).

**NOTE:** The shade of red in the test region (T) may vary, but it should be considered negative whenever there is even a faint pink line.

**POSITIVE: One red line appears in the control region (C).**

No line appears in the test region. This positive result indicates that the Benzoyllecgonine concentration is above the detectable level (300 ng/mL).

**INVALID: Control line fails to appear.** Insufficient specimen volume or incorrect procedural techniques are the most likely reasons for control line failure. Review the procedure and repeat the test with a new test Cassette. If the problem persists, discontinue using the test kit immediately and contact your local distributor.

## QUALITY CONTROL

A procedural control is included in the test. A red line appearing in the control region (C) is considered an internal procedural control. It confirms sufficient specimen volume and correct procedural technique.

Control standards are not supplied with this kit; however, it is recommended that positive and negative controls be tested as a good laboratory practice to confirm the test procedure and to verify proper test performance.

## LIMITATION

1. Atlas One Step Cocaine Test Cassette (Urine) provides only a qualitative, preliminary analytical result. A secondary quantitative analytical method must be used to obtain a confirmed result. Gas chromatography/mass spectrometry (GC/MS) is the preferred confirmatory method.
2. It is possible that technical or procedural errors, as well as other interfering substances in the urine specimen may cause erroneous results.
3. Adulterants, such as bleach and/or alum, in urine specimens may produce erroneous results regardless of the analytical method used. If adulteration is suspected, the test should be repeated with another urine specimen.
4. A positive result does not indicate level of intoxication, administration route or concentration in urine.
5. A negative result may not necessarily indicate drug-free urine. Negative results can be obtained when drug is present but below the cut-off level of the test.
6. Test does not distinguish between drugs of abuse

and certain medications.

## PERFORMANCE CHARACTERISTICS

### Accuracy

A side-by-side comparison was conducted by laboratory personnel using Atlas One Step Cocaine Test Cassette (Urine) and a commercially available rapid test. Testing was performed on specimens previously collected from subjects presenting for Drug Screen Testing. Presumptive positive results were confirmed by GC/MS. The following results were tabulated:

Method	Results	Other COC Rapid Test		Total Results
		Positive	Negative	
Atlas One Step Cocaine	Positive	136	0	136
	Negative	7	157	164
Total Results		143	157	300
% Agreement with this commercial kit		95%	>99%	98%

When compared to GC/MS at the cut-off of 300 ng/mL, the following results were tabulated:

Method	Results	GC/MS		Total Results
		Positive	Negative	
Atlas One Step Cocaine Test Cassette	Positive	119	17	136
	Negative	5	159	164
Total Results		124	176	300
% Agreement with GC/MS Analysis		96%	90%	93%

### Analytical Sensitivity

A drug-free urine pool was spiked with Benzoyllecgonine at the following concentrations: 0 ng/mL, 150 ng/mL, 225 ng/mL, 300 ng/mL, 375 ng/mL and 450 ng/mL. The result demonstrates 100% accuracy at 50% above and 50% below the cut-off concentration. The data are summarized below:

Benzoyllecgonine Concentration (ng/mL)	Percent of Cut-off	n	Visual	Result
			Negative	Positive
0	0	30	30	0
150	-50%	30	30	0
225	-25%	30	30	0
300	Cut-off	30	4	26
375	+25%	30	0	30
450	+50%	30	0	30

### Analytical Specificity

The following table lists compounds that are positively detected in urine by Atlas One Step Cocaine Test Cassette (Urine) at 5 minutes.

Compound	Concentration (ng/ml)
Benzoyllecgonine	300
Cocaine HCl	780

Cocaethylene	12500
Ecgonine HCl	32000

## BIBLIOGRAPHY

Stewart DI, T Inoba, M Ducassen, W Kalow. Clin. Pharmacol. Ther. 1979; 25:264  
Ambre J. J. Anal. Toxicol. 1985; 9:241  
Baselt RC. Disposition of Toxic Drugs and Chemicals in Man. 2nd Ed. Biomedical Publ., Davis, CA. 1982: 488  
Hawks RL, CN Chiang. *Urine Testing for Drugs of Abuse*. National Institute for Drug Abuse (NIDA), Research Monograph 73, 1986

## ATLAS MEDICAL

William James House, Cowley Rd,  
Cambridge, CB4 4WX, UK  
Tel: ++44 (0) 1223 858 910  
Fax: ++44 (0) 1223 858 524

PPI236A01  
Revision A (26.09.2005)